

RJP30H2DPK-M0 / RJP30H2A

Silicon N Channel IGBT
High speed power switching

R07DS0467EJ0200
Rev.2.00
Jun 15, 2011

Features

- Trench gate and thin wafer technology (G6H-II series)
- Low collector to emitter saturation voltage: $V_{CE(sat)} = 1.4$ V typ
- High speed switching: $t_f = 100$ ns typ, $t_r = 180$ ns typ
- Low leak current: $I_{CES} = 1$ μ A max

Outline

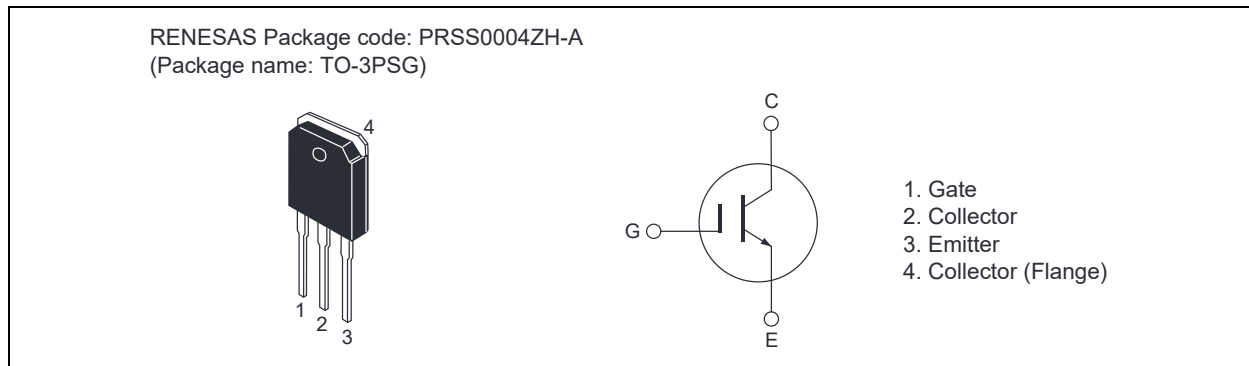

Absolute Maximum Ratings

($T_a = 25^\circ\text{C}$)

Item	Symbol	Ratings	Unit
Collector to Emitter voltage	V_{CES}	360	V
Gate to Emitter voltage	V_{GES}	± 30	V
Collector current	I_c	35	A
Collector peak current	$i_{c(peak)}$ ^{Note1}	250	A
Collector dissipation	P_C ^{Note2}	60	W
Junction to case thermal impedance	θ_{j-c}	2.08	$^\circ\text{C}/\text{W}$
Junction temperature	T_j	150	$^\circ\text{C}$
Storage temperature	T_{stg}	-55 to +150	$^\circ\text{C}$

- Notes: 1. $PW \leq 10$ μ s, duty cycle $\leq 1\%$
2. $T_c = 25^\circ\text{C}$

Electrical Characteristics

(Ta = 25°C)

Item	Symbol	Min	Typ	Max	Unit	Test Conditions
Zero gate voltage collector current	I_{CES}	—	—	1	μA	$V_{CE} = 360\text{ V}, V_{GE} = 0$
Gate to emitter leak current	I_{GES}	—	—	± 100	nA	$V_{GE} = \pm 30\text{ V}, V_{CE} = 0$
Gate to emitter cutoff voltage	$V_{GE(off)}$	2.5	—	5	V	$V_{CE} = 10\text{ V}, I_C = 1\text{ mA}$
Collector to emitter saturation voltage	$V_{CE(sat)}$	—	1.4	1.9	V	$I_C = 35\text{ A}, V_{GE} = 15\text{ V}$ ^{Note3}
Input capacitance	C_{ies}	—	1200	—	pF	$V_{CE} = 25\text{ V}$
Output capacitance	C_{oes}	—	60	—	pF	$V_{GE} = 0$
Reveres transfer capacitance	C_{res}	—	30	—	pF	$f = 1\text{ MHz}$
Total gate charge	Q_g	—	37	—	nC	$V_{GE} = 15\text{ V}$
Gate to emitter charge	Q_{ge}	—	6	—	nC	$V_{CE} = 150\text{ V}$
Gate to collector charge	Q_{gc}	—	10	—	nC	$I_C = 35\text{ A}$
Switching time	$t_{d(on)}$	—	0.02	—	μs	$I_C = 35\text{ A}$
	t_r	—	0.1	—	μs	$R_L = 4.5\ \Omega$
	$t_{d(off)}$	—	0.06	—	μs	$V_{GE} = 15\text{ V}$
	t_f	—	0.18	—	μs	$R_G = 5\ \Omega$

Notes: 3. Pulse test.

Main Characteristics

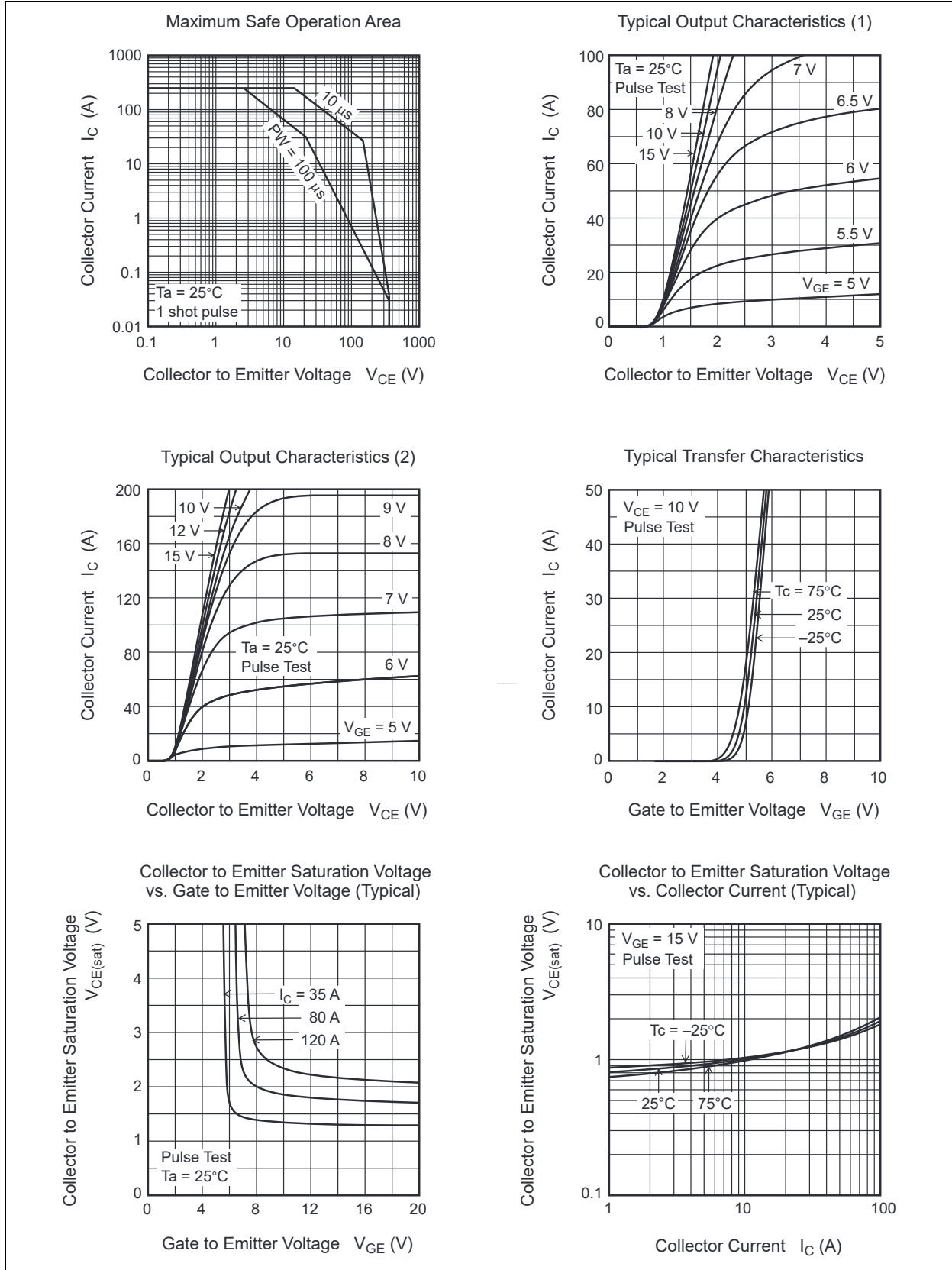

Typical Capacitance vs. Collector to Emitter Voltage

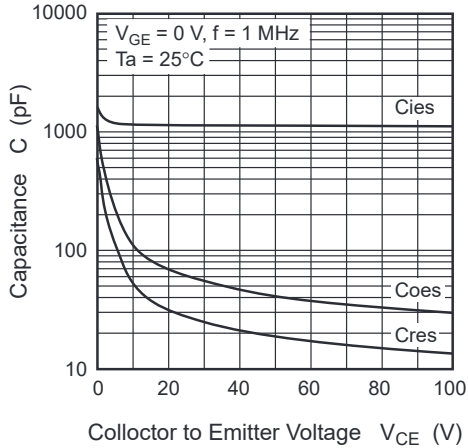

Dynamic Input Characteristics (Typical)

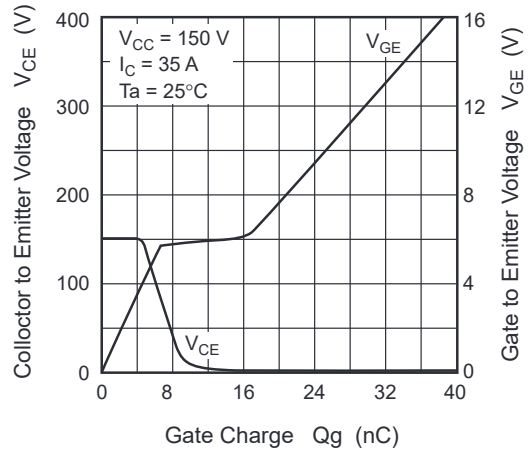

Switching Characteristics (Typical) (1)

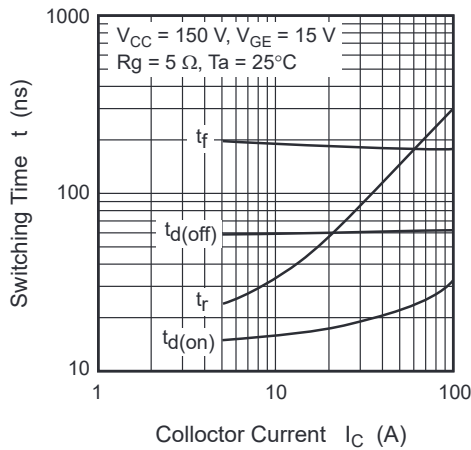

Switching Characteristics (Typical) (2)

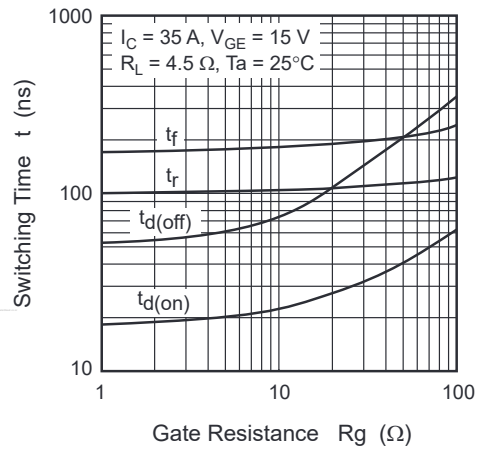

Switching Characteristics (Typical) (3)

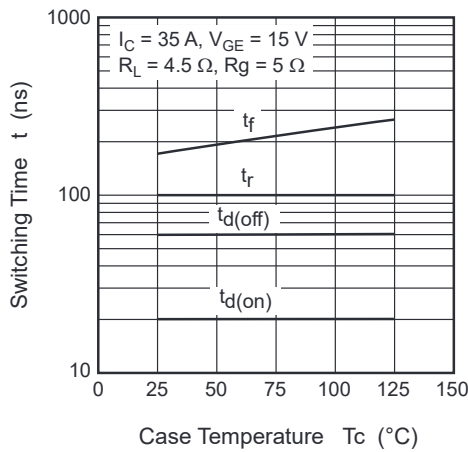

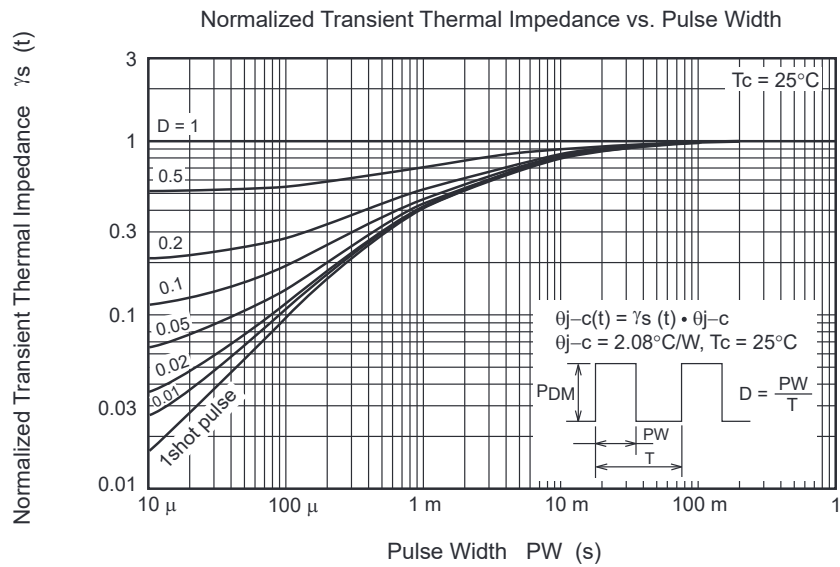

Switching Time Test Circuit

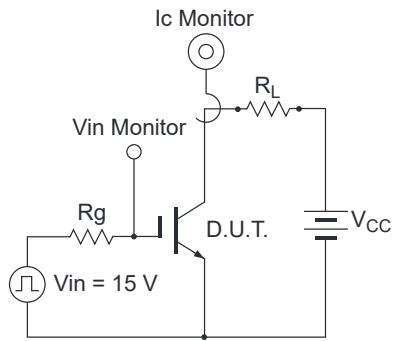

Waveform

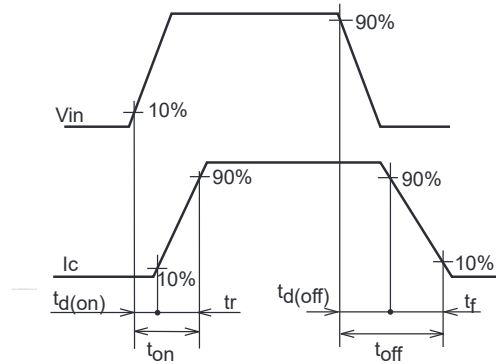

Package Dimension

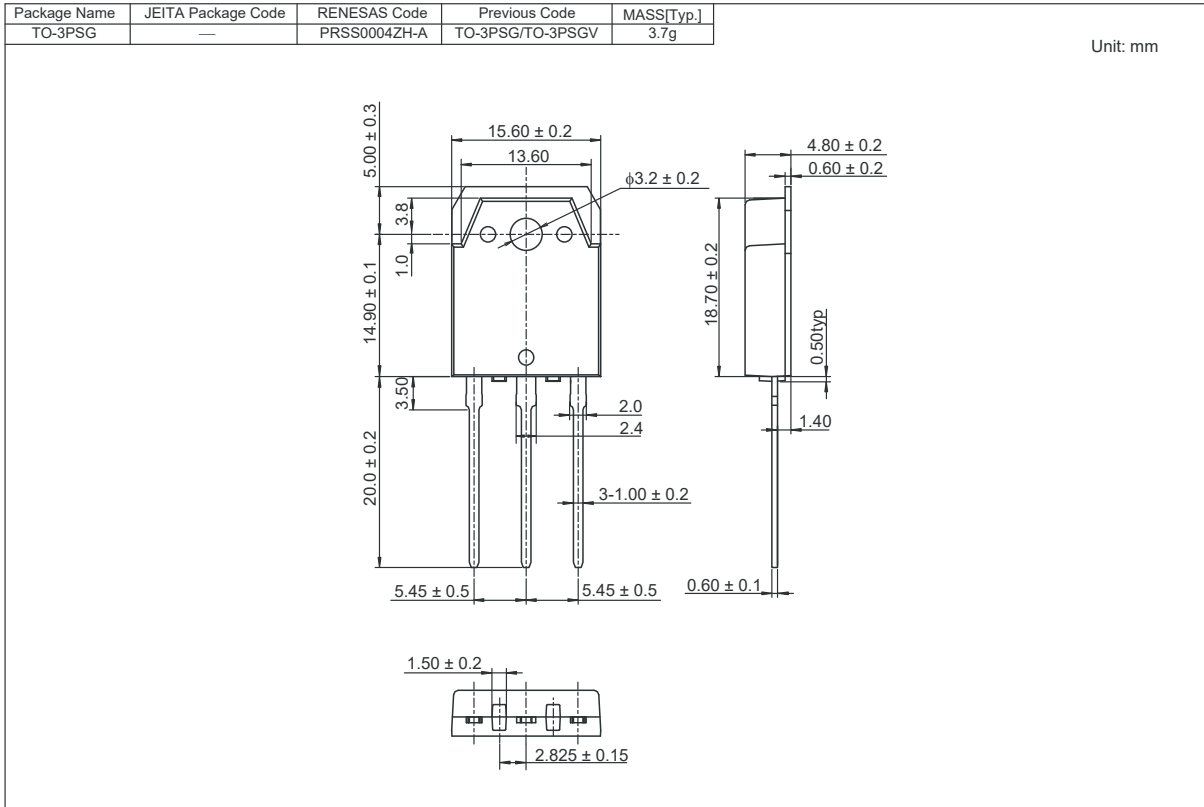

Package
Part Number: RJP30H2A

